



markilux 970

**Aesthetics and technology rolled into one –
the compact cassette awning with clean, clear lines.**

Purist, angular, attractive

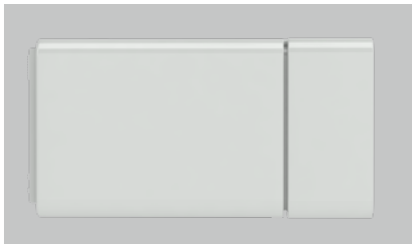

01
02
03
04
05side view
top fixturethe awning pitch
can be adjusted
from 5° to 30°side view
eaves fixturethe wind safety
mechanism in the
tilt device ensures
safe operationside view
face fixturethe markilux
bionic tendon
made of high-tech
fibres for optimum
power transference

Design Features

compact, rectangular cassette

modern, purist design suited to current architectural styles with straight lines and a clear concept

attractive appearance thanks to the torque bar-free construction

compact housing only 140 mm in height

the special cassette shape surrounds the roller tube even when the awning is extended so lending the awning a closed and overall harmonious appearance

the panel joints of the awning cover are ultrasonically bonded – giving an improved appearance without bothersome stitching

when retracted, the cover is protected from the weather by the cassette, which encloses it completely

Technical Specification

when the awning is closed, the folding arms are protected inside the front profile

folding arms with perfected power transference by means of the innovative bionic tendon

the 85 mm roller tube ensures the highest rigidity and the best possible cover winding characteristics even at the largest widths

folding arms with drop-forged, aluminium joint components and Teflon-coated bronze bushes, which provide superior robustness and durability

the new and unique fixture technology makes installation simple and easy

simple pitch adjustment of 5° to 30° via the tilt device

Accessories

hard-wired motor drive for simple, relaxed operation by means of a wall switch

radio-controlled motor with radio remote control for ease of use

automatic sun and wind controls

in the case of manual operation, ease of use is ensured with the spring-assisted gearbox

the optional lighting in energy-efficient technology (LED spotlights) provides a striking atmosphere under the awning

awning available in non-standard RAL colours

various front panel colours which contrast with the standard Lounge or RAL colour of the frame are available without surcharge

Lighting options



LED spotlights underneath the cassette

Radio control options LED lighting

	Somfy RTS (433 MHz)	Somfy io (868 MHz)
LED spotlights	on / off / dimmable standard	on / off / dimmable optional

Frame colours / Front panel colours (upper description / lower description)

traffic white RAL 9016
traffic white RAL 9016



metallic aluminium RAL 9006
stone grey metallic 5215



stone grey metallic 5215
anthracite metallic 5204



off-white textured finish 5233
anthracite metallic 5204



anthracite metallic 5204
anthracite metallic 5204



anthracite metallic 5204
stone grey metallic 5215



Examples: The colour of the front panel (lower description) can be combined at will with all standard Lounge and RAL colours to match or contrast with the awning colour (upper description).

Additional front panel colours

By way of example, all possible front panel colours are shown below with the frame colour traffic white RAL 9016. The front panel colours can be combined at will with all standard, non-standard Lounge and RAL colours.

anodised aluminium E6 / EV1

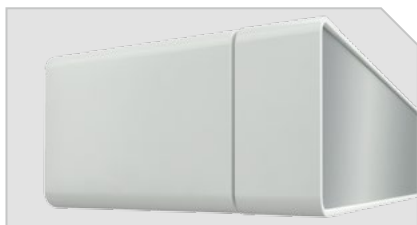

sulphur yellow RAL 1016

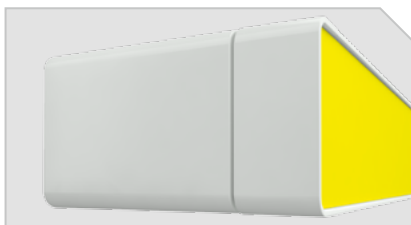

traffic red RAL 3020

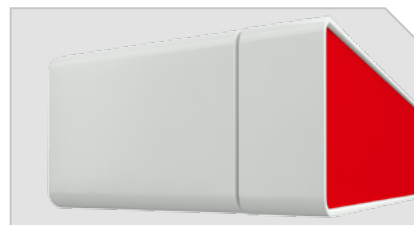

pitch black RAL 9005

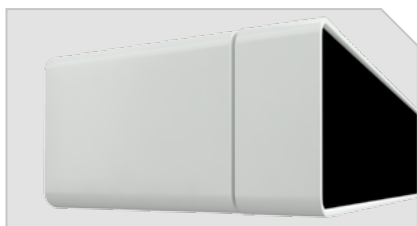

yellow green RAL 6018

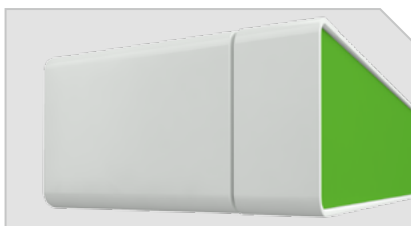



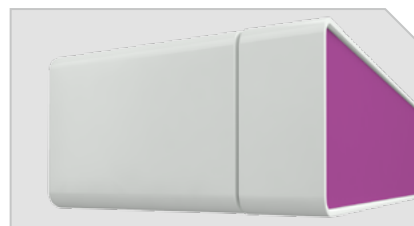

traffic purple RAL 4006

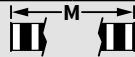
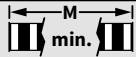

- 01
- 02
- 03
- 04
- 05

Dimensions and configuration options

										
	250	300	350	400	450	500	550	600		
	195 250	251 300	301 350	351 400	401 450	451 500	501 550	551 600		
	150								195*	195
	200	1)							245*	245
	250	—	1)						295*	295
	300	—	—	1)					345*	345
	350	—	—	—	1)			—	395*	395

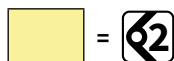

1) please note the minimum widths! Dimensions in cm







Operation / drive unit

	standard	optional
manual operation	<input checked="" type="checkbox"/>	—
servo-assisted operation	—	<input checked="" type="checkbox"/>
motor	—	<input checked="" type="checkbox"/>
io Radio controls	—	<input checked="" type="checkbox"/>
radio-controlled motor (433 MHz)	—	<input checked="" type="checkbox"/>







Covers

	fabric range no.	standard	optional
sunsilk snc	324 .. / 328 .. / 369 ..	<input checked="" type="checkbox"/>	—
sunsilk perla FR	374 ..	—	<input checked="" type="checkbox"/>
sunvas snc	310 .. / 311 .. 313 .. — 315 ..	<input checked="" type="checkbox"/>	—
sunvas perla	370 ..	—	<input checked="" type="checkbox"/>

Frame and front panel colours

	standard	optional
traffic white RAL 9016		
metallic aluminium RAL 9006		
anthracite metallic 5204		
stone grey metallic 5215		
off-white textured finish 5233		
Havana brown textured finish 5229		
non-standard powder-coated finish		

Additional front panel colours

	standard	optional
anodised aluminium E6 / EV1		
sulphur yellow RAL 1016		
traffic red RAL 3020		
pitch black RAL 9005		
yellow green RAL 6018		
traffic purple RAL 4006		

Colours similar to those in the RAL chart. Colours may differ slightly from those depicted in both hue and finish.

Dimensions and tolerances

	width	nominal extension
housing tolerances	+ 5 / - 5 mm	± 40 mm
awning cover width	M - 320 mm	
awning cover length	H + 130 mm	



Miscellaneous

	standard	optional
light and wind sensor	—	<input checked="" type="checkbox"/>
vibrabox* / radio control light sensor Sunis WireFree	—	<input checked="" type="checkbox"/>

*The vibrabox can only be positioned in the centre, between the arms. If a vibrabox is required the minimum width increases by 15 cm.

Additional Information

The width of the awning cover is always **less** than that of the awning. **Pitch adjustment range:** 5° to 30°. In the case of manual operation **approximately 16 winding handle revolutions** can be assumed **per metre of awning projection**. It takes approximately **12 seconds per metre** to extend a **motor-driven awning**. This model is only available as a single unit.

M = overall awning width	M min. = minimum width	H = extension
 = no. of folding arms	 = motor	 = manual operation

Fixtures, fittings and accessories

Face fixture brackets

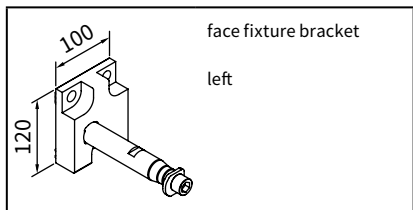

face fixture bracket
left

72826.

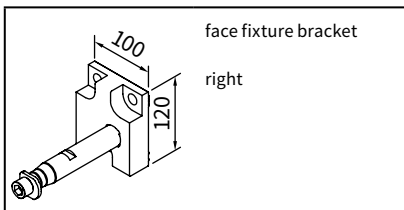

face fixture bracket
right

72827.

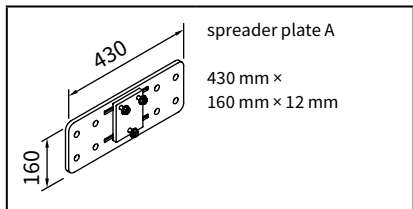

spreader plate A
430 mm ×
160 mm × 12 mm

72870.

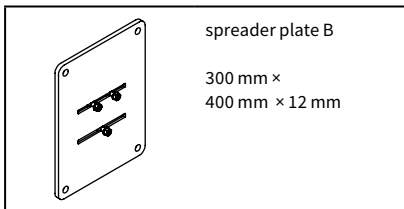

spreader plate B
300 mm ×
400 mm × 12 mm

75325.

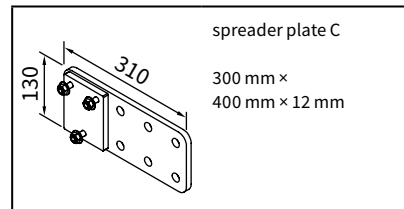

spreader plate C
300 mm ×
400 mm × 12 mm

72526.

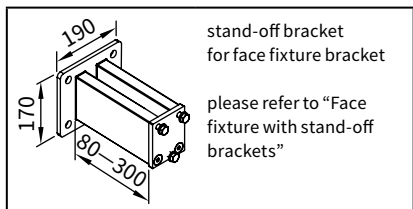

stand-off bracket
for face fixture bracket
please refer to "Face
fixture with stand-off
brackets"

72872.

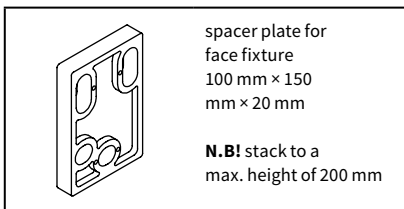

spacer plate for
face fixture
100 mm × 150
mm × 20 mm
N.B! stack to a
max. height of 200 mm

718231

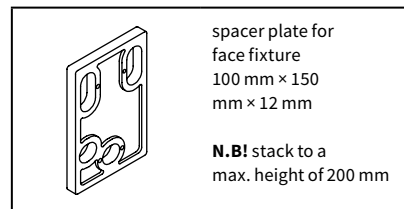

spacer plate for
face fixture
100 mm × 150
mm × 12 mm
N.B! stack to a
max. height of 200 mm

718241

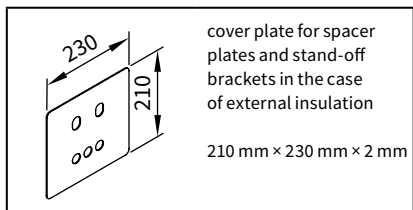

cover plate for spacer
plates and stand-off
brackets in the case
of external insulation
210 mm × 230 mm × 2 mm

71843.

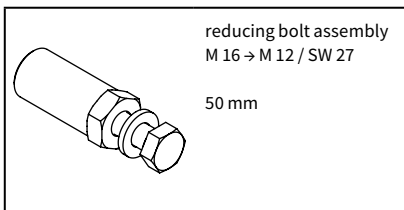

reducing bolt assembly
M 16 → M 12 / SW 27
50 mm

753891

Top fixture brackets

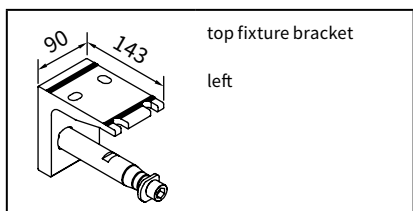

top fixture bracket
left

72860.

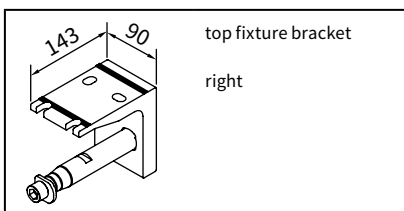

top fixture bracket
right

72861.

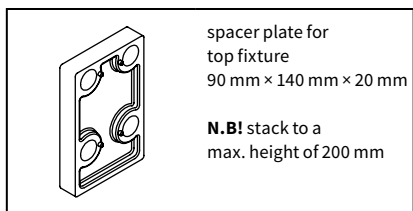

spacer plate for
top fixture
90 mm × 140 mm × 20 mm
N.B! stack to a
max. height of 200 mm

716311

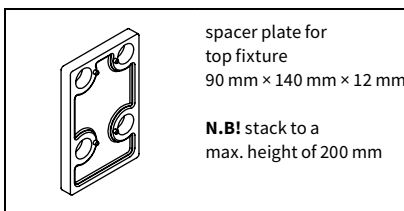

spacer plate for
top fixture
90 mm × 140 mm × 12 mm
N.B! stack to a
max. height of 200 mm

716411

. = insert RAL colour code no.

- 01
- 02
- 03
- 04
- 05

Fixtures, fittings and accessories

Eaves fixture brackets

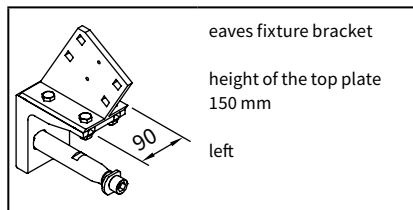

eaves fixture bracket
height of the top plate
150 mm
left

72874.

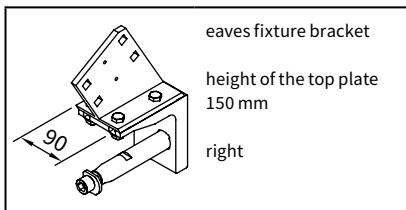

eaves fixture bracket
height of the top plate
150 mm
right

72875.

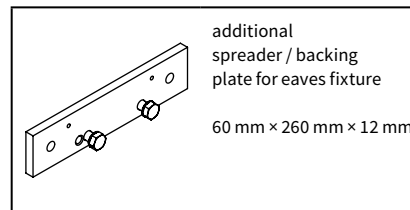

additional
spreader / backing
plate for eaves fixture
60 mm × 260 mm × 12 mm

75383.

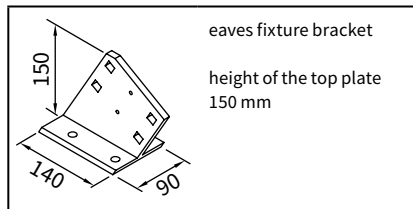

eaves fixture bracket
height of the top plate
150 mm

71612.

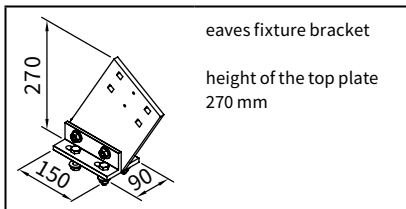

eaves fixture bracket
height of the top plate
270 mm

71659.

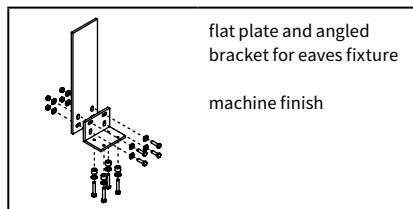

flat plate and angled
bracket for eaves fixture
machine finish

716620

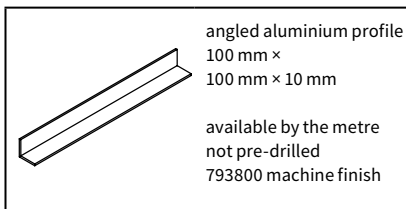

angled aluminium profile
100 mm ×
100 mm × 10 mm
available by the metre
not pre-drilled
793800 machine finish

79380.

Accessories

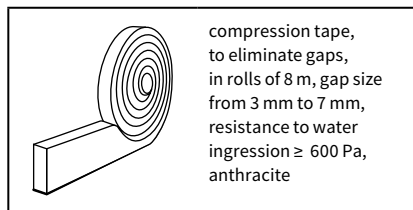

compression tape,
to eliminate gaps,
in rolls of 8 m, gap size
from 3 mm to 7 mm,
resistance to water
ingression ≥ 600 Pa,
anthracite

795721

. = insert RAL colour code no.

Face fixture

Pull-out force [N=Newton] per upper fixing point according to EN 13561, wind resistance class 2

compression-proof substrate									non compression-proof substrate							
M [cm]									M [cm]							
250 300 350 400 450 500 550 600									250 300 350 400 450 500 550 600							
H [cm]	FB [N]								FB [N]							
150	691	805	919	1033	1148	1262	1376	1490	729	850	970	1091	1211	1332	1452	1573
200	1084	1256	1429	1601	1774	1947	2119	2292	1144	1326	1508	1690	1873	2055	2237	2419
250	—	1745	1986	2227	2469	2710	2951	3193	—	1842	2097	2351	2606	2861	3115	3370
300	—	—	2632	2952	3272	3592	4343	4704	—	—	2778	3116	3454	3792	4584	4966
350	—	—	—	3863	4272	5211	—	—	—	—	—	4077	4509	5500	—	—

HT BHT	2 100 mm								2 100 mm							
BM	6								6							

The pull-out forces shown apply when the vertical centre to centre measurement between the fixture points is 90 mm. If this measurement is reduced to the minimum, the pull-out force increases by up to 3 % in the case of **compression-proof** substrates and by up to 7 % in the case of **non-compression-proof** substrates.

- M = overall awning width
- H = nominal projection
- FB = pull-out force per fixing point
- HT | BHT = bracket quantity | width
- BM = no. of fixing points
- 72826. = face fixture bracket, left
- 72827. = face fixture bracket, right
- 795721 = compression tape
- BA = width between fixture points
- MB = bracket fixture range
- SV = silicon seal

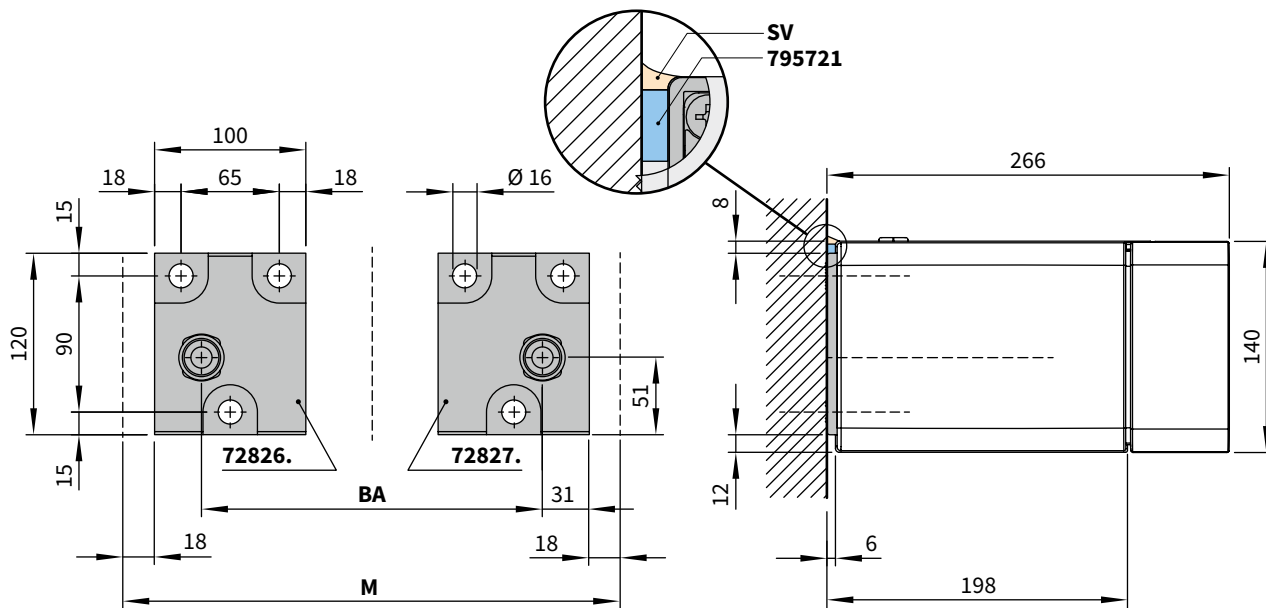

Face fixture and the use of compression tape

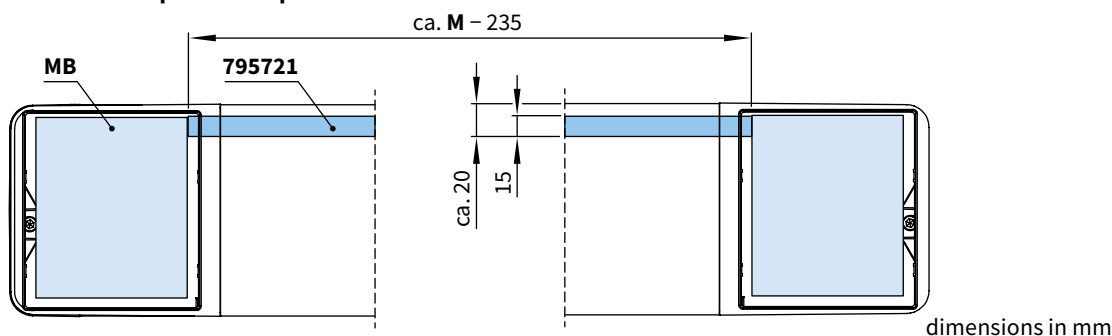

dimensions in mm

01
02
03
04
05

Face fixture with spreader plate A

Pull-out force [N=Newton] per upper fixing point according to EN 13561, wind resistance class 2

compression-proof substrate
M [cm]

H [cm]	250	300	350	400	450	500	550	600
150	311	362	414	465	516	567	619	670
200	485	563	640	717	794	871	949	1026
250	—	779	887	994	1102	1210	1317	1425
300	—	—	1172	1315	1457	1600	1935	2096
350	—	—	—	1718	1900	2318	—	—

non compression-proof substrate
M [cm]

H [cm]	250	300	350	400	450	500	550	600
150	442	515	588	661	733	806	879	952
200	690	799	909	1019	1129	1238	1348	1458
250	—	1107	1260	1413	1566	1719	1872	2025
300	—	—	1666	1869	2071	2274	2749	2978
350	—	—	—	2441	2700	3294	—	—

HT BHT	2 100 mm
BP	2
BM	16

HT BHT	2 100 mm
BP	2
BM	16

The pull-out forces shown apply when the vertical centre to centre measurement between the fixture points is **76 mm**.
In the case of spreader plates a washer conforming to DIN 9021 must be used.

- M = overall awning width 72870. = spreader plate A
- H = nominal projection
- FB = pull-out force per fixing point
- HT | BHT = bracket quantity | width
- BP = no. of spreader plates
- BM = no. of fixing points

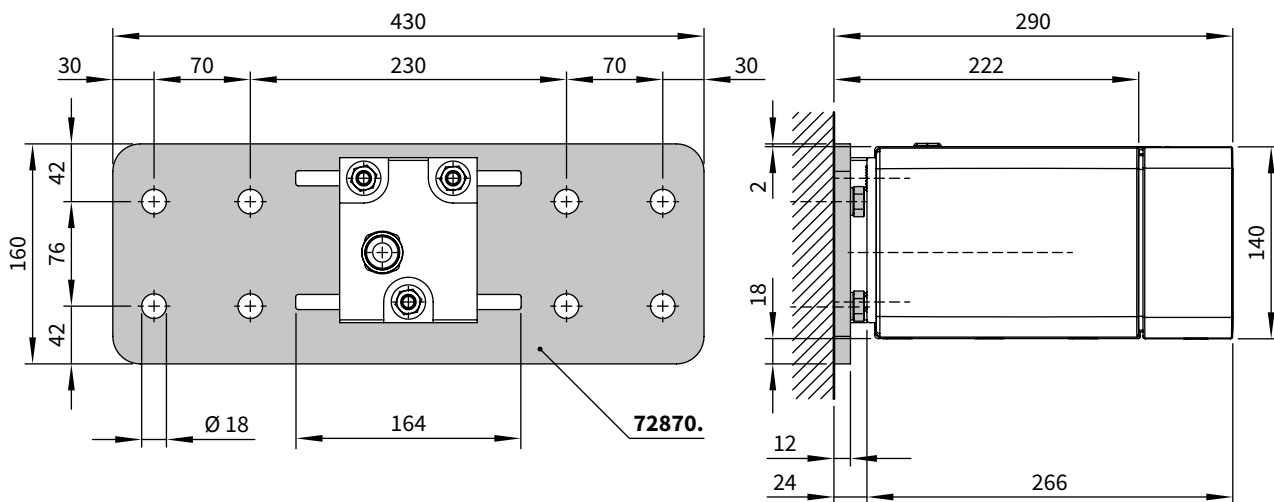

dimensions in mm

Face fixture with spreader plate B

Pull-out force [N=Newton] per upper fixing point according to EN 13561, wind resistance class 2

compression-proof substrate									non compression-proof substrate								
M [cm]									M [cm]								
250 300 350 400 450 500 550 600									250 300 350 400 450 500 550 600								
H [cm]	FB [N]								FB [N]								
150	182	212	242	272	302	332	362	392	190	221	252	284	315	346	378	409	
200	285	330	375	421	466	511	557	602	297	344	391	439	486	533	580	628	
250	—	458	521	584	647	711	774	837	—	477	543	609	675	741	807	873	
300	—	—	689	773	857	941	1138	1232	—	—	719	806	894	981	1186	1285	
350	—	—	—	1011	1118	1364			—	—	—	1054	1166	1422	—	—	

HT BHT	2 100 mm
BP	2
BM	8

The pull-out forces shown apply when the vertical centre to centre measurement between the fixture points is **350 mm**. In the case of spreader plates a washer conforming to DIN 9021 must be used.

- M = overall awning width 75325. = spreader plate B
- H = nominal projection
- FB = pull-out force per fixing point
- HT | BHT = bracket quantity | width
- BP = no. of spreader plates
- BM = no. of fixing points

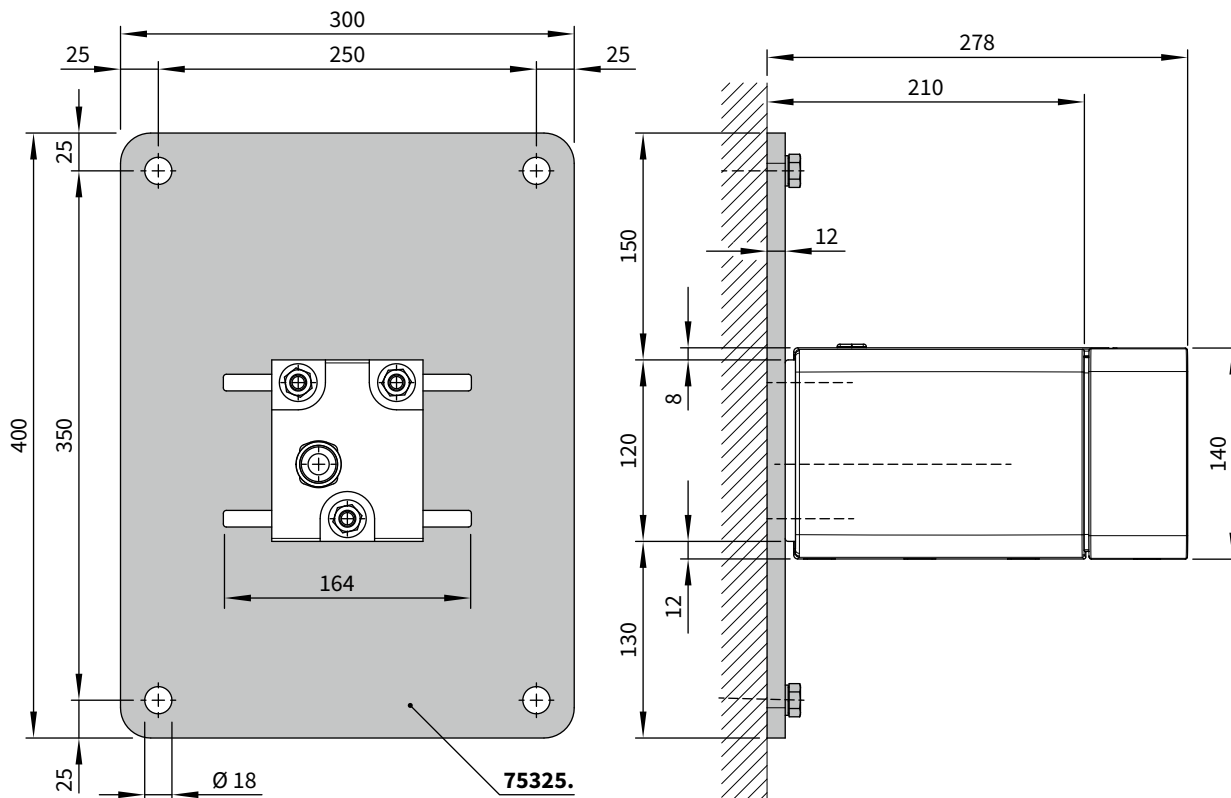

dimensions in mm

01
02
03
04
05

Face fixture with spreader plate C

Pull-out force [N=Newton] per upper fixing point according to EN 13561, wind resistance class 2

compression-proof substrate
M [cm]

H [cm]	250	300	350	400	450	500	550	600
150	481	561	640	720	799	879	958	1037
200	751	871	991	1110	1230	1349	1469	1589
250	—	1206	1373	1539	1706	1873	2040	2206
300	—	—	1815	2036	2257	2477	2996	3245
350	—	—	—	2660	2942	3589	—	—

non compression-proof substrate
M [cm]

H [cm]	250	300	350	400	450	500	550	600
150	589	686	783	881	978	1075	1172	1270
200	920	1066	1212	1359	1505	1651	1798	1944
250	—	1476	1680	1884	2088	2292	2496	2700
300	—	—	2221	2492	2762	3032	3666	3971
350	—	—	—	3255	3600	4392	—	—

HT BHT	2 100 mm
BP	2
BM	12

HT BHT	2 100 mm
BP	2
BM	12

The pull-out forces shown apply when the vertical centre to centre measurement between the fixture points is **76 mm**.
In the case of spreader plates a washer conforming to DIN 9021 must be used.

- M = overall awning width 72526. = spreader plate C
- H = nominal projection
- FB = pull-out force per fixing point
- HT | BHT = bracket quantity | width
- BP = no. of spreader plates
- BM = no. of fixing points

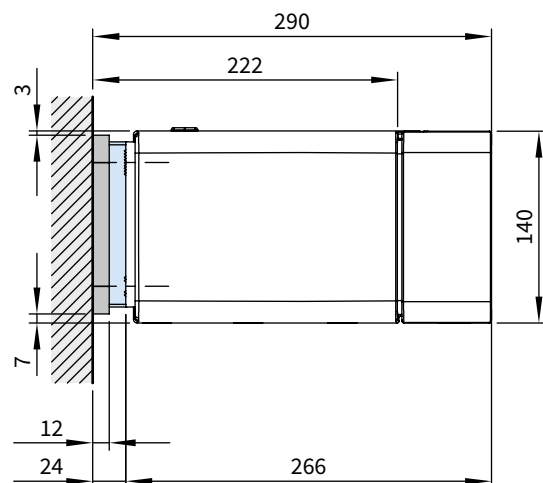
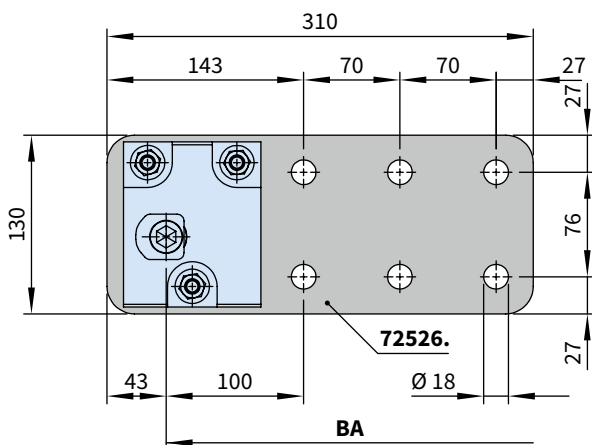

dimensions in mm

Face fixture with stand-off brackets

Pull-out force [N=Newton] per upper fixing point according to EN 13561, wind resistance class 2

compression-proof substrate									non compression-proof substrate								
M [cm]									M [cm]								
250 300 350 400 450 500 550 600									250 300 350 400 450 500 550 600								
H [cm]	FB [N]								FB [N]								
150	633	736	839	942	1044	1147	1250	1353	712	827	943	1059	1175	1291	1407	1523	
200	944	1093	1242	1390	1539	1687	1836	1985	1062	1230	1397	1564	1731	1898	2066	2233	
250	—	1468	1669	1871	2072	2273	2475	2676	—	1651	1878	2104	2331	2557	2784	3011	
300	—	—	2160	2421	2683	2944	3569	3866	—	—	2430	2724	3018	3312	4016	4349	
350	—	—	—	3115	3443	4209	—	—	—	—	—	3504	3873	4735	—	—	

HT BHT	2 100 mm
DH 72872.	2
BM	8

The pull-out forces shown apply when the vertical centre to centre measurement between the fixture points is **120 mm**. In the case of stand-off brackets washers conforming to DIN 9021 must be used.

- M = overall awning width
 - H = nominal projection
 - FB = pull-out force per fixing point
 - HT | BHT = bracket quantity | width
 - BM = no. of fixing points
 - DH = no. of stand-off brackets
- 72872.** = stand-off brackets for face fixture brackets 72826. and 72827.

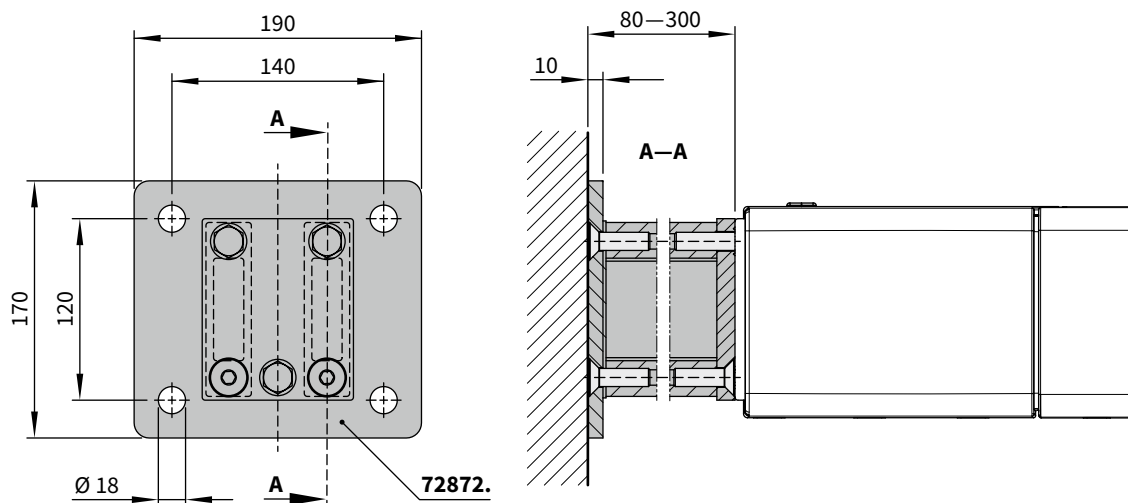

dimensions in mm

- 01
- 02
- 03
- 04
- 05

Top fixture

Pull-out force [N=Newton] per upper fixing point according to EN 13561, wind resistance class 2

compression-proof substrate
M [cm]

H [cm]	250	300	350	400	450	500	550	600
150	609	712	815	918	1021	1124	1227	1330
200	920	1069	1219	1368	1517	1666	1815	1965
250	—	1456	1660	1863	2067	2271	2474	2678
300	—	—	2171	2437	2703	2969	3576	3874
350	—	—	—	3158	3495	4250	—	—

non compression-proof substrate
M [cm]

H [cm]	250	300	350	400	450	500	550	600
150	883	1031	1179	1327	1475	1623	1771	1920
200	1349	1567	1784	2002	2219	2437	2654	2872
250	—	2147	2446	2745	3044	3343	3642	3941
300	—	—	3213	3606	3998	4391	5295	5737
350	—	—	—	4687	5186	6313	—	—

HT BHT	2 90 mm
BM	8

HT BHT	2 90 mm
BM	8

The pull-out forces shown apply when the horizontal centre to centre measurement between the fixture points is **80 mm**.

- M = overall awning width
- H = nominal projection
- FB = pull-out force per fixing point
- HT | BHT = bracket quantity | width
- BM = no. of fixing points
- BA = width between fixture points
- 72860.** = top fixture bracket, **left**
- 72861.** = top fixture bracket, **right**

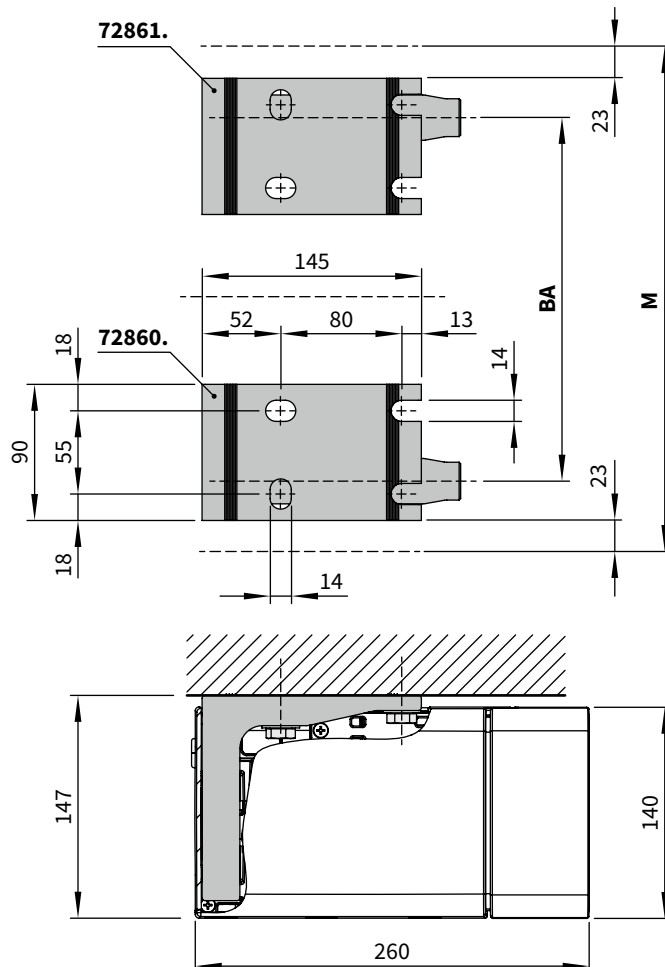

dimensions in mm

Eaves fixture

Torque [Nm = Newton metres] for the fixture bracket next to the arm, shear force [N = Newton] per fixing point according to EN 13561, wind resistance class 2

H [cm]	Torque M [cm]								Shear force M [cm]							
	250	300	350	400	450	500	550	600	250	300	350	400	450	500	550	600
	Md [Nm]								FS [N]							
150	131	153	175	196	218	240	261	283	1583	1850	2116	2382	2648	2914	3180	3446
200	206	239	271	304	337	370	403	436	2412	2802	3191	3581	3970	4360	4749	5139
250	—	332	377	423	469	515	561	607	—	3834	4368	4902	5437	5971	6506	7040
300	—	—	500	561	622	683	825	894	—	—	5732	6432	7133	7834	9443	10232
350	—	—	—	734	812	990	—	—	—	—	—	8355	9244	11250	—	—
HT	2								2							
BM	8								8							

The shear force is calculated on the basis of 2 fixture points per bracket, because – depending on the roof pitch – it cannot be guaranteed that 4 fixture points per bracket can be used.

- M = overall awning width
- H = nominal projection
- Md = torque value for the bracket in the immediate vicinity of the arm
- HT = no. of brackets per track
- FS = shear force
- BM = no. of fixing points

- 72874.** = eaves fixture bracket, complete, 150 mm, left
- 72875.** = eaves fixture bracket, complete, 150 mm, right
- 71612.** = eaves fixture bracket, height of the top plate 150 mm
- 71659.** = eaves fixture bracket, height of the top plate 270 mm

with eaves fixture bracket 150 mm

with eaves fixture bracket 270 mm

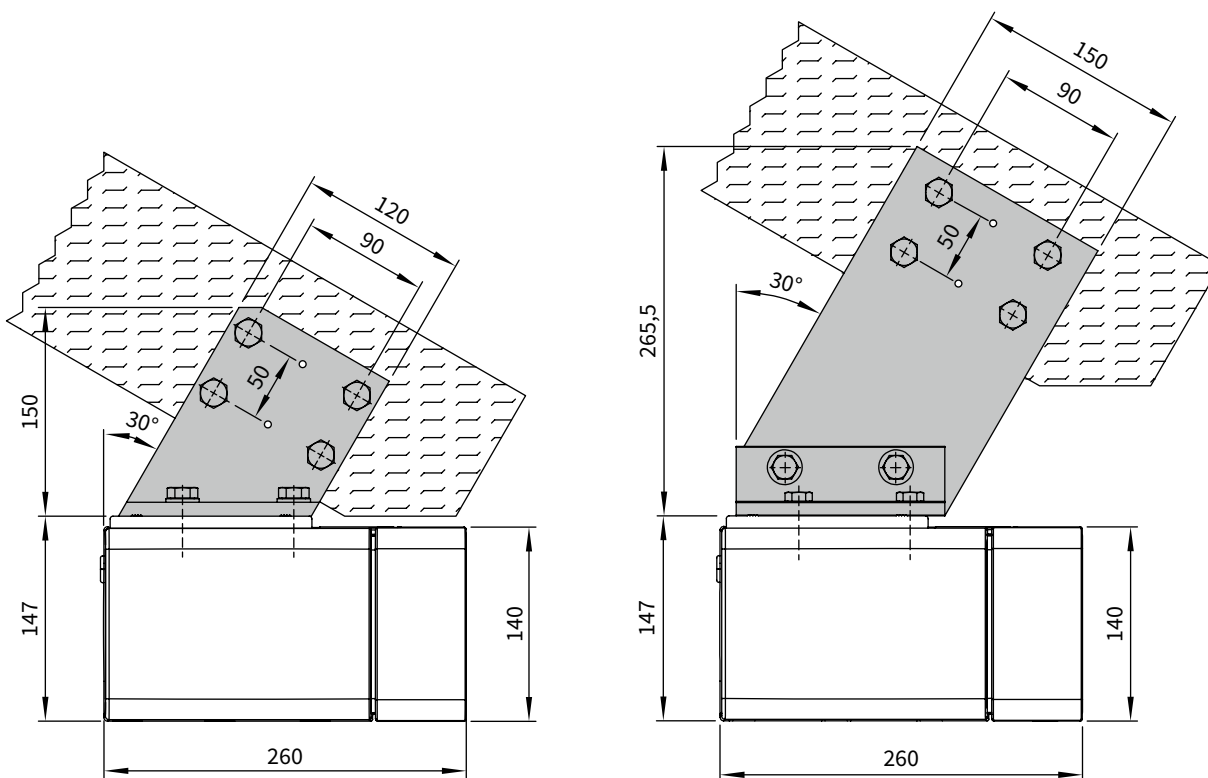

dimensions in mm

01
02
03
04
05

Eaves fixture with additional spreader / backing plate

Torque [Nm = Newton metres] for the fixture bracket next to the arm, shear force [N = Newton] per fixing point according to EN 13561, wind resistance class 2

H [cm]	Torque M [cm]								Shear force M [cm]							
	250	300	350	400	450	500	550	600	250	300	350	400	450	500	550	600
	FB [N]								FB [N]							
150	131	153	175	196	218	240	261	283	781	915	1048	1182	1315	1449	1582	1716
200	206	239	271	304	337	370	403	436	1154	1343	1532	1721	1910	2099	2288	2478
250	—	332	377	423	469	515	561	607	—	1808	2062	2316	2570	2825	3079	3333
300	—	—	500	561	622	683	825	894	—	—	2675	3005	3334	3663	4401	4769
350	—	—	—	734	812	990	—	—	—	—	—	3870	4283	5200	—	—
HT	2								2							
BM	4								4							

By using the additional flat fixture plate, the shear force is reduced in comparison with conventional eaves fixture.

M = overall awning width

H = nominal projection

Md = torque value for the bracket in the immediate vicinity of the arm

HT = no. of brackets per track

FS = shear force

BM = no. of fixing points

75383. = additional spreader / backing plate

for eaves fixture

60 mm × 260 mm × 12 mm

with eaves fixture bracket 150 mm

with eaves fixture bracket 270 mm

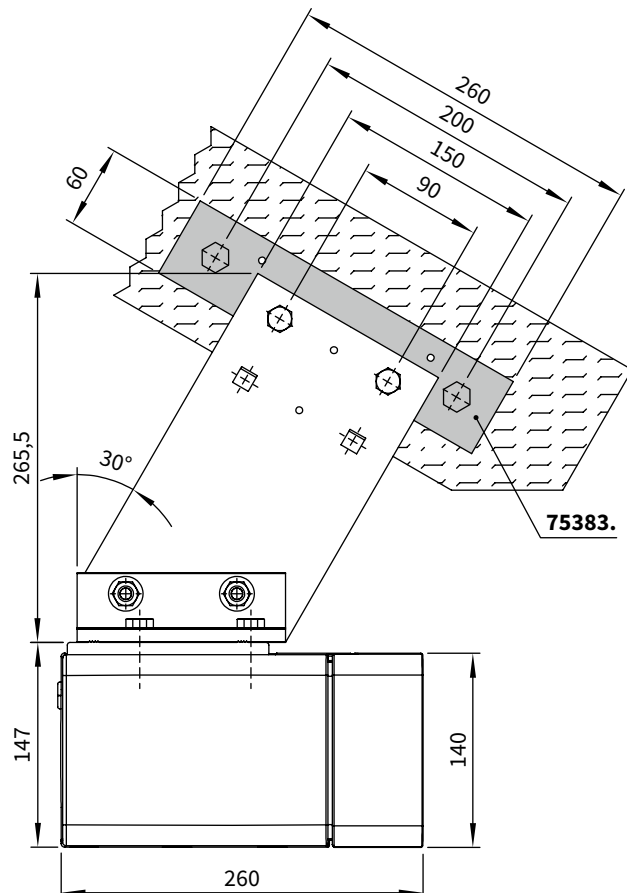
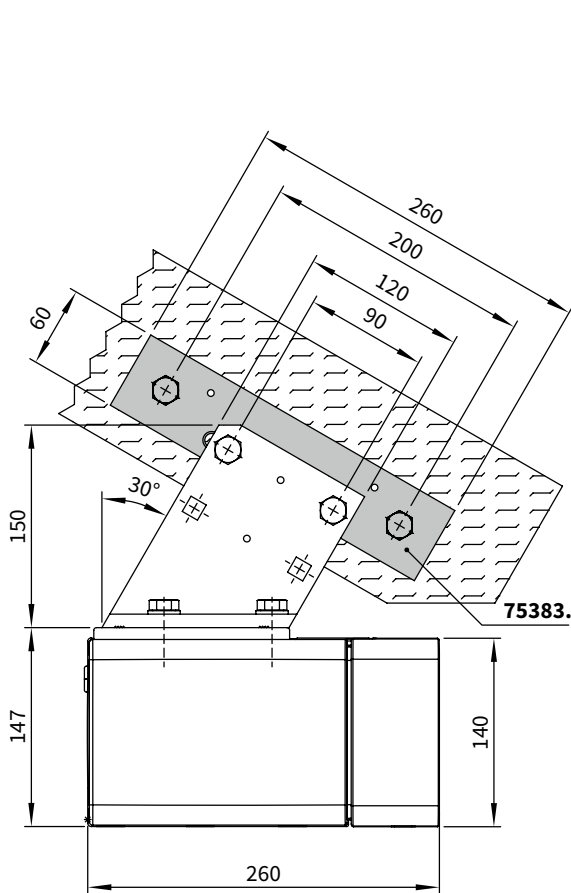

dimensions in mm

Recess fixture

- 01
- 02
- 03
- 04
- 05

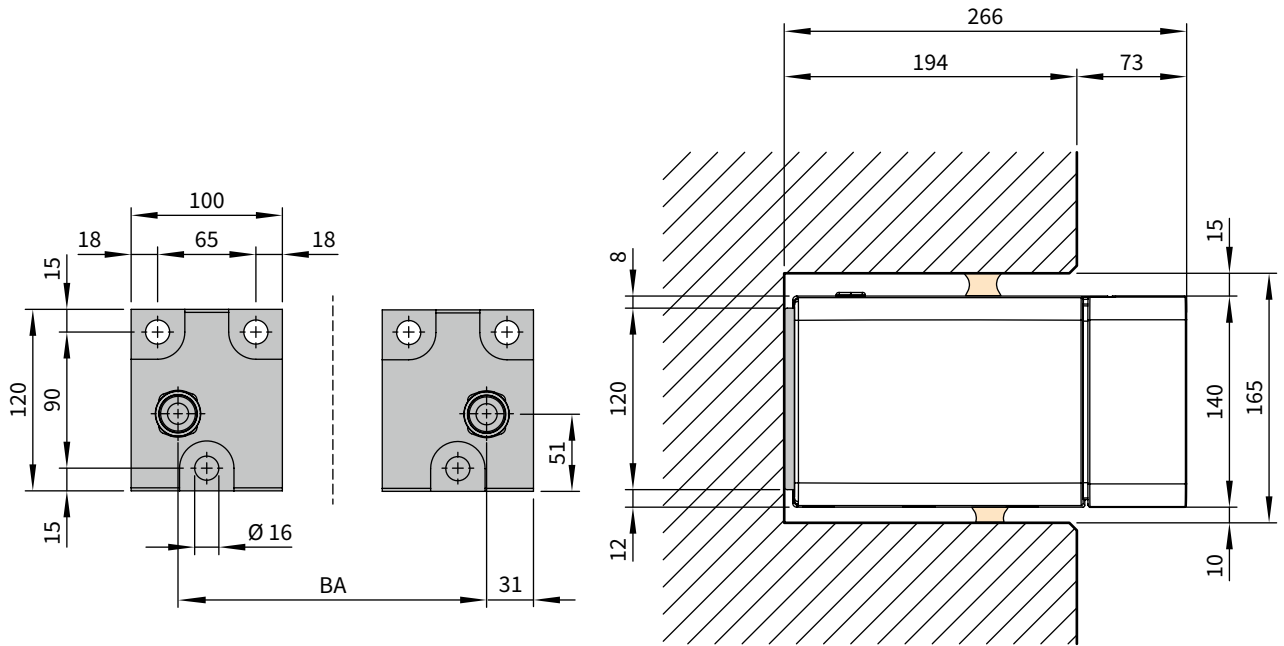

72826. = face fixture bracket, left

72827. = face fixture bracket, right

dimensions in mm

Manual operation when using face fixture

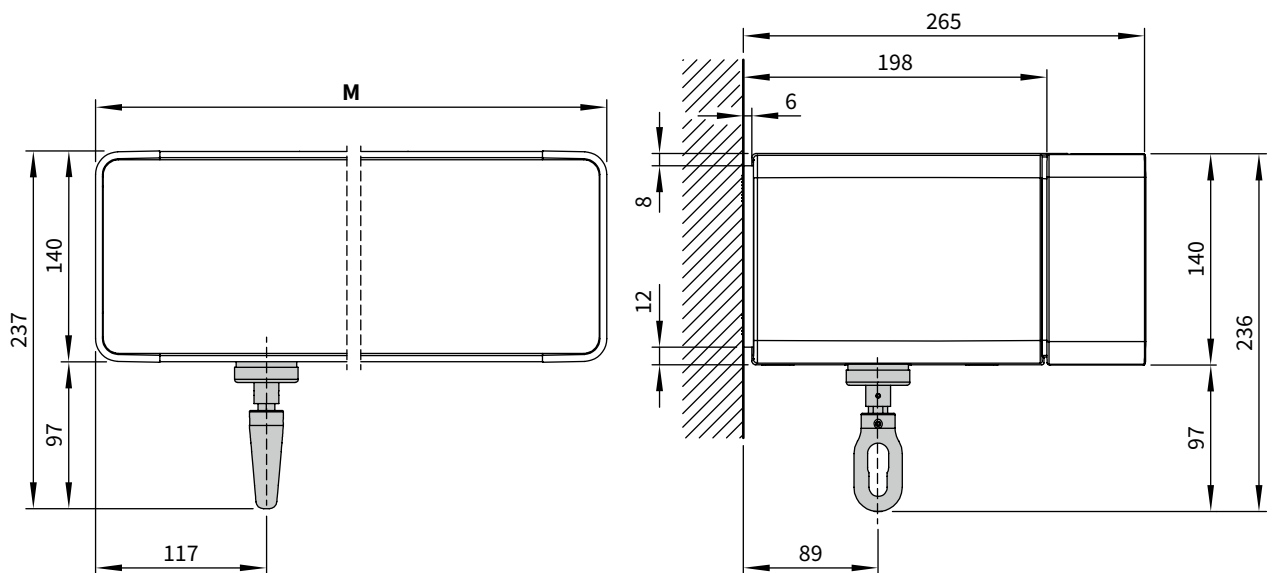

dimensions in mm

M = overall awning width = order width of the folding-arm awning

BA = width between fixture points

- 01
- 02
- 03
- 04
- 05

Lighting options

LED spotlights

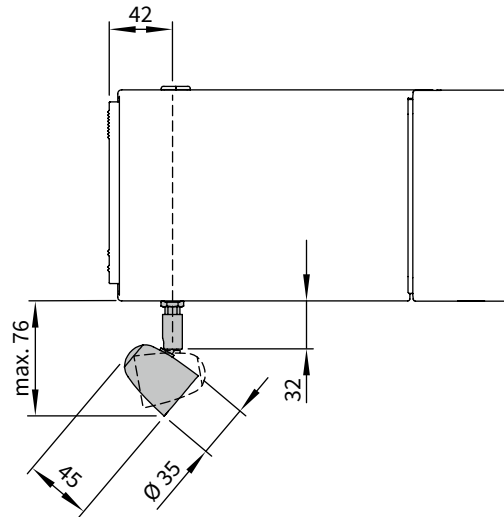

dimensions in mm

Dimensions / No. of LED spotlights

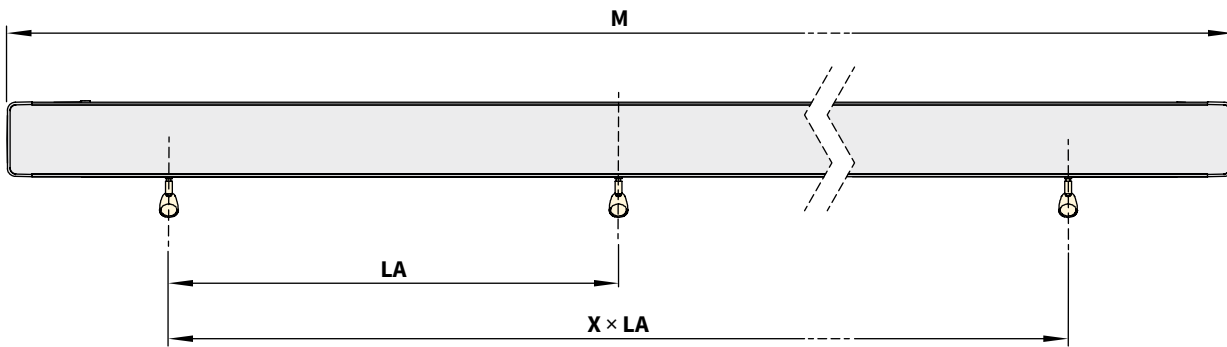

M (mm)	Number of spotlights	LA (mm)
1950–2500	3	750
2501–3000	3	980
3001–3500	3	980
3501–4000	4	980
4001–4500	4	980
4501–5000	5	980
5001–5500	5	980
5501–6000	6	980

Technical data markilux LED spotlights

operating voltage	230 V, 50 Hz
power output per spotlight	5 W
light source	LED (12 V)
number of transformers	1 piece
light temperature	2700 K, warm white
IP protection class	IP 44
energy efficiency class	A bis A++
service life	approx. 20,000 h

K O (H* SPL

Diese Leuchte enthält eingebaute LED-Lampen.

A++
A+
A
B
C
D
E

LED

Die Lampen können in der Leuchte nicht ausgetauscht werden.

874/2012

M = overall awning width

LA = spotlight separation

Cable exit point in the case of top fixture

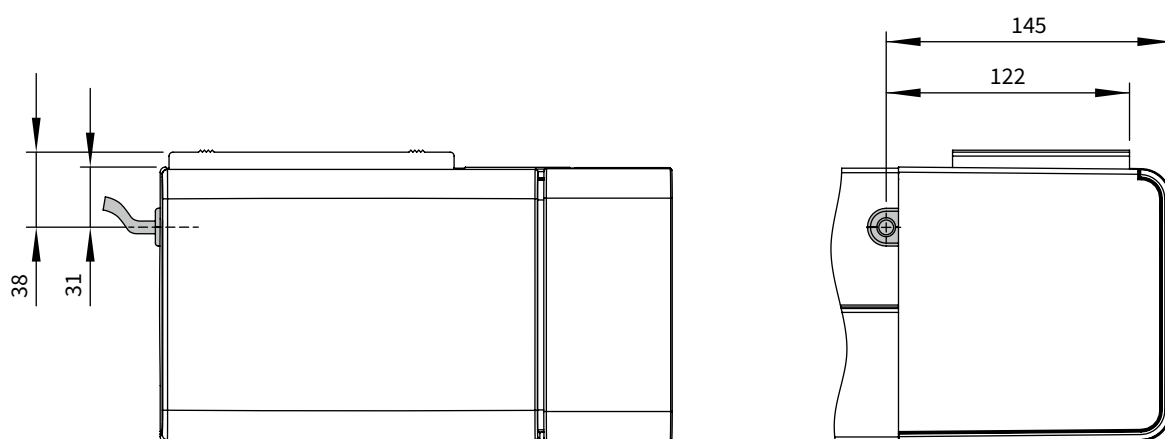

dimensions in mm

Cable exit point in the case of face fixture

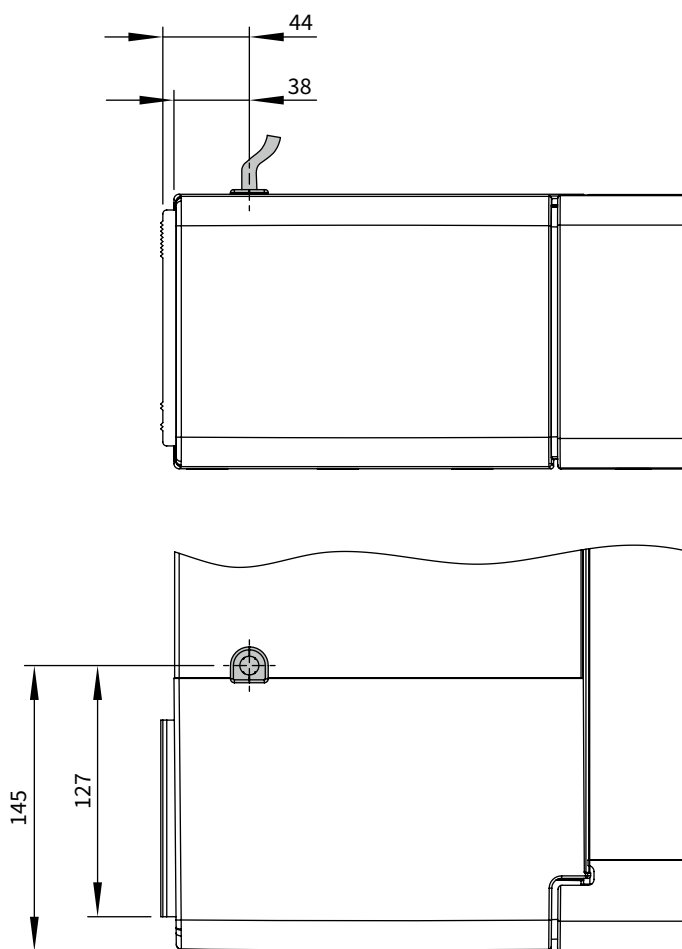

dimensions in mm

- 01
- 02
- 03
- 04
- 05

- 01
- 02
- 03
- 04
- 05

Bracket fixture range in the case of top fixture

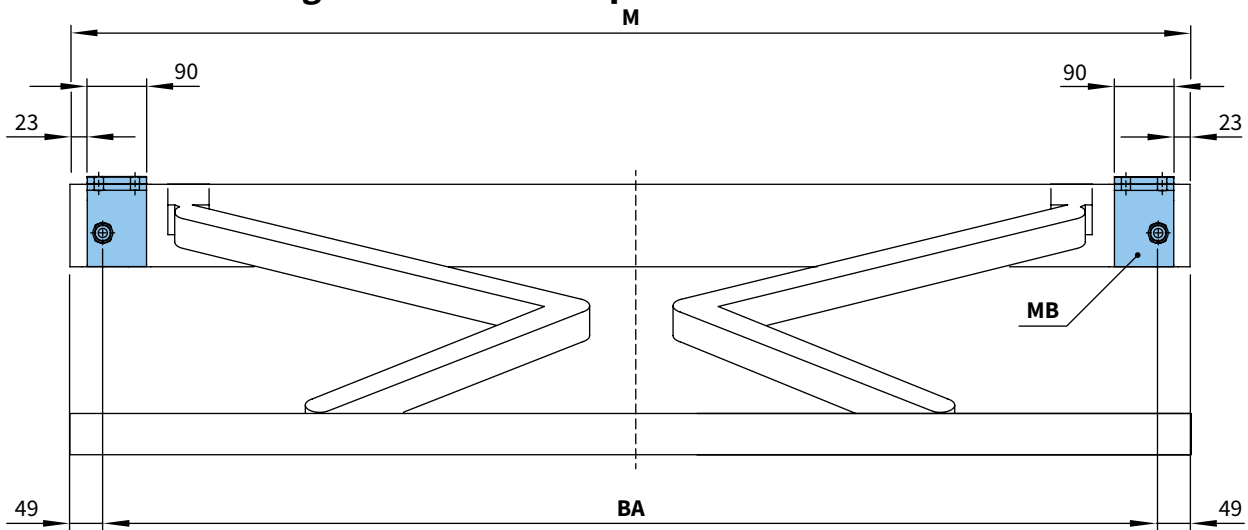

dimensions in mm

Bracket fixture range in the case of face fixture

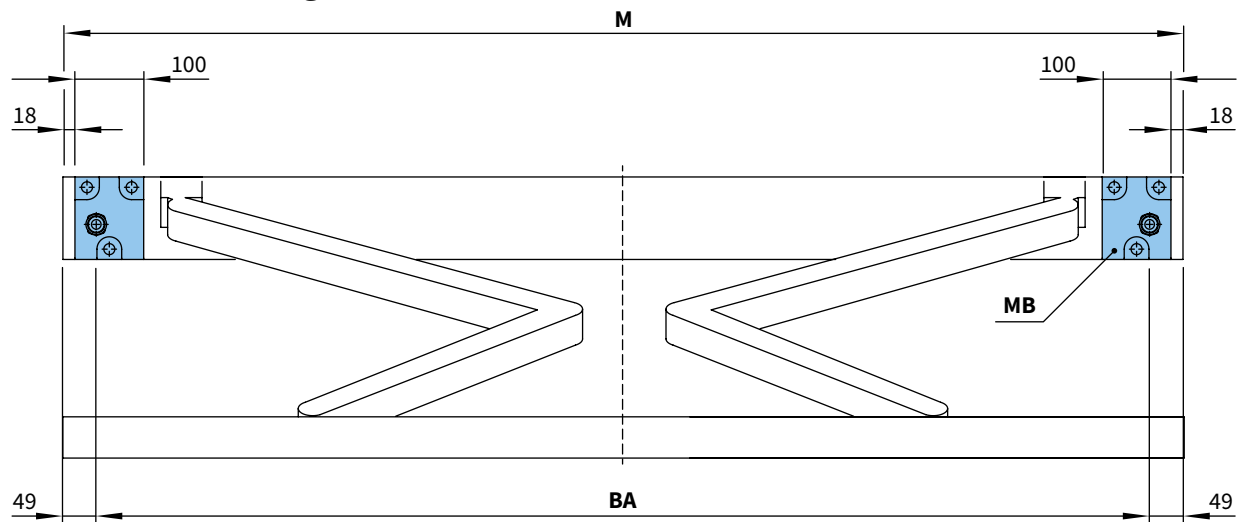

dimensions in mm

Bracket fixture range in the case of eaves fixture

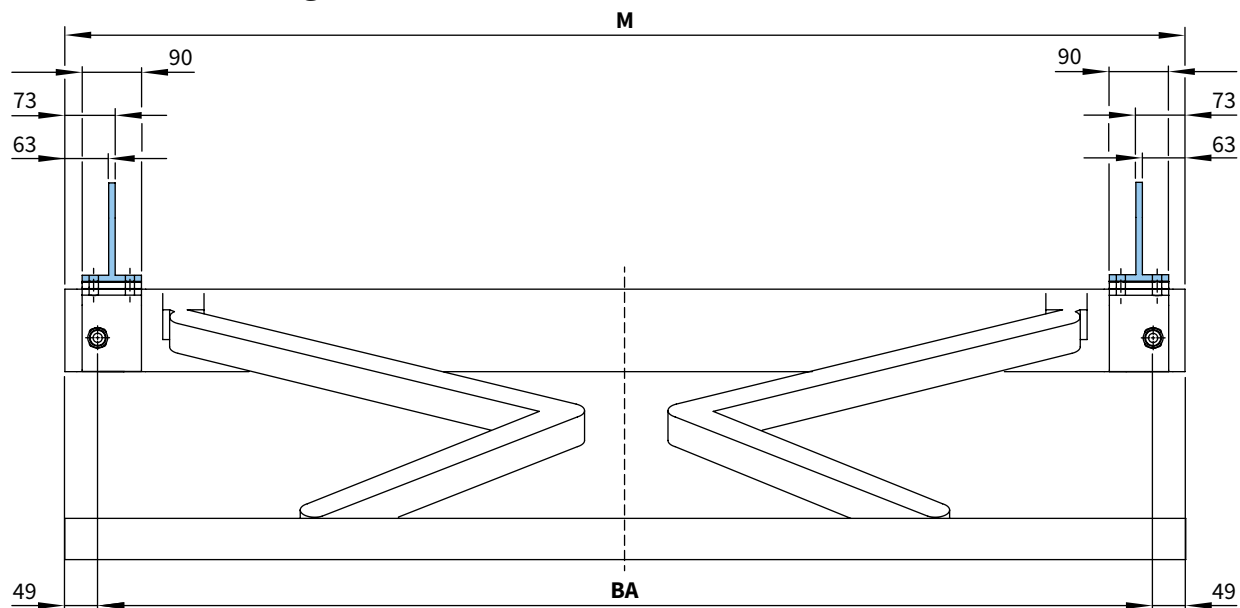

dimensions in mm

M = awning width = order width of the folding-arm awning

MB = bracket fixture range

BA = width between fixture points